

IBM System x™ and BladeCenter®

Why System x and BladeCenter for Virtualisation?

Chris Tapsell
Technical Sales Specialist
IBM UK Ltd

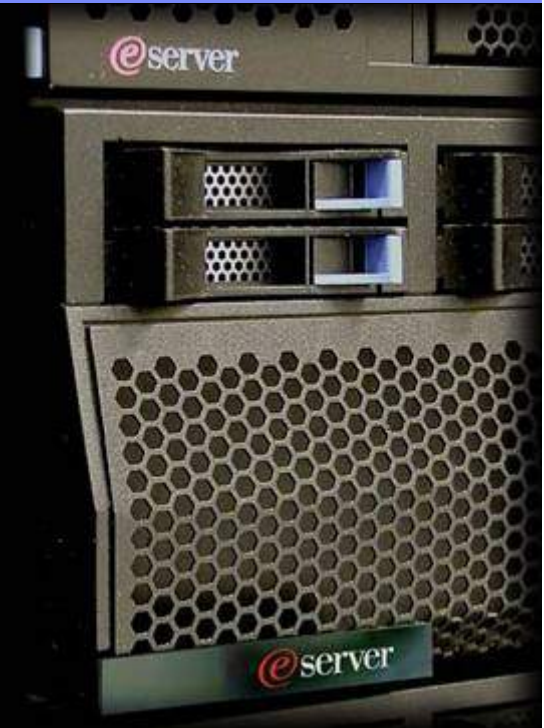

Agenda

- Virtualisation & hardware requirements
- High End / Scale Up:
 - x3850 M2 / x3950 M2 - X4 Architecture
- BladeCenter / Blades / Scale Out
 - BladeCenter H and HS21 XM Blade



Virtualisation and hardware requirements

- Number and performance of CPUs
- Memory capacity & throughput
- Network and storage I/O
- Manageability / redundancy and resilience



Technology Innovation & Trends

- **Multi-core Processors Multiply**
 - 2 cores in 2005-6, 4 cores in 2006-7, 6 cores by end 2008?
- **Virtualized computing moves to mainstream solutions**
 - Virtualization solutions will enable customers to lower their total cost of operations by improving the utilization of their hardware and labor costs
- **Power Management**
 - Server power is approaching limits of thermal, acoustic, and power density
 - Active power management is key to managing future power
- **RAID and Disks**
 - Wide requirement for Standard RAID - top to bottom of portfolio
 - Serial Attached SCSI (SAS) replaces parallel SCSI
 - 2.5-inch drives grow dramatically in 2007/2008
 - Solid state disks
- **Network Offload Technologies (Broadcom TOE or Intel IOAT)**
 - Offloads protocol processing from CPU to a separate engine, improves processor efficiency
- **Fully Buffered DIMMS ?**
 - Faster speeds, higher peak bandwidth than DDR2
- **PCI-Express**
 - Adoption rate will increase in 2006-2008

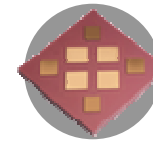

Multi Core



Virtualization



Manageability



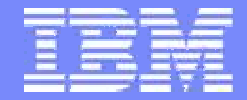

High end / Scale-up servers

Forth Generation
Enterprise X-Architecture



System x

Industry-leading Performance, Reliability and Control

AMD

x3755



**Ultra HPC/BPC
Compute Node**

- Unmatched price/performance and leadership design
- Maximum configurable I/O slots
- Flexible configurations for outstanding 3 CPU performance
- Fastest, largest memory capacity

x3800



**Optimized for
SMB Distributed
Computing**

- Ultimate all-in-one distributed computing performance
- Maximum internal storage capacity
- X3 ingenuity in a tower form factor

x3850

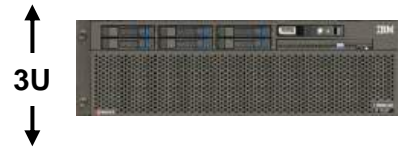

**Leadership RAS features
for commercial
applications**

- 64-bit addressability for ERP/CRM applications
- More memory capacity for virtualized applications

x3950



**Fastest x64
Database Server**

- Pay-as-you-grow SMP technology with partition flexibility
- Entry price point 10's of thousands, not 100's of thousands
- Add incremental capacity with diskless MXE expansion chassis
- Offers scalability for database performance 'headroom'

IBM X4 Based x3850 M2 and x3950 M2

Single Node Features

- 4U Rack-optimized server w/Intel quad-core processors
 - Support for Xeon Series 7300 (Tigerton) processors
 - X4 chip set with FSB 1066 MHz
 - Leadership commercial performance
- 32 DIMM Slots, DDR2/533MHz
 - 1/2/4 & 8GB DIMM support (max:256GB)
 - Xcelerated Memory Technology drives all slots @ 533MHz
- 7 PCI-e 8x half-length slots (2 hot-swap)
- SAS Storage
 - Controller (RAID 0/1 Std. RAID 5 Opt.)
 - 4 hot-swap 2.5" HDDs
- Dual port Gb Ethernet w/TOE, iSCSI & RDMA
- On-board management controller delivers full remote presence capability
- ALL x3850 M2 models are field upgradeable to x3950 M2



Multi-node Capabilities

- Four-node multi-chassis system scalability
 - 16 processor sockets (64 cores)
 - 128 memory DIMMs (1TB)
 - 28 PCI-e I/O slots

- X4 ScaleXpander option kit
- Simplified engineering software updates

More IBM Differentiation

- Memory subsystem with DDR2
 - Largest x86 Memory capacity (Flexible Multi-chassis design enables 64 DIMM 4-processor and 128 DIMM 8-processor configurations)
 - Up to 23% less power consumption and up to 20% faster
- Memory ProteXion Technology
 - Uses spare DIMM bits provide protection
 - Double the error recovery of Chipkill
- Embedded Hypervisor – VMWare 3i
 - Allows system to boot as virtualized platform
 - Eliminates hours of primary partition installation activities
- Automated Support Advantage Program
 - Call home service for proactive / rapid problem ID and response (Year 1 complimentary, Service offering available for years 2 & 3)
 - Assistance with Director and system software configuration
 - Direct access to level 2 support

Start Running VMs in Minutes

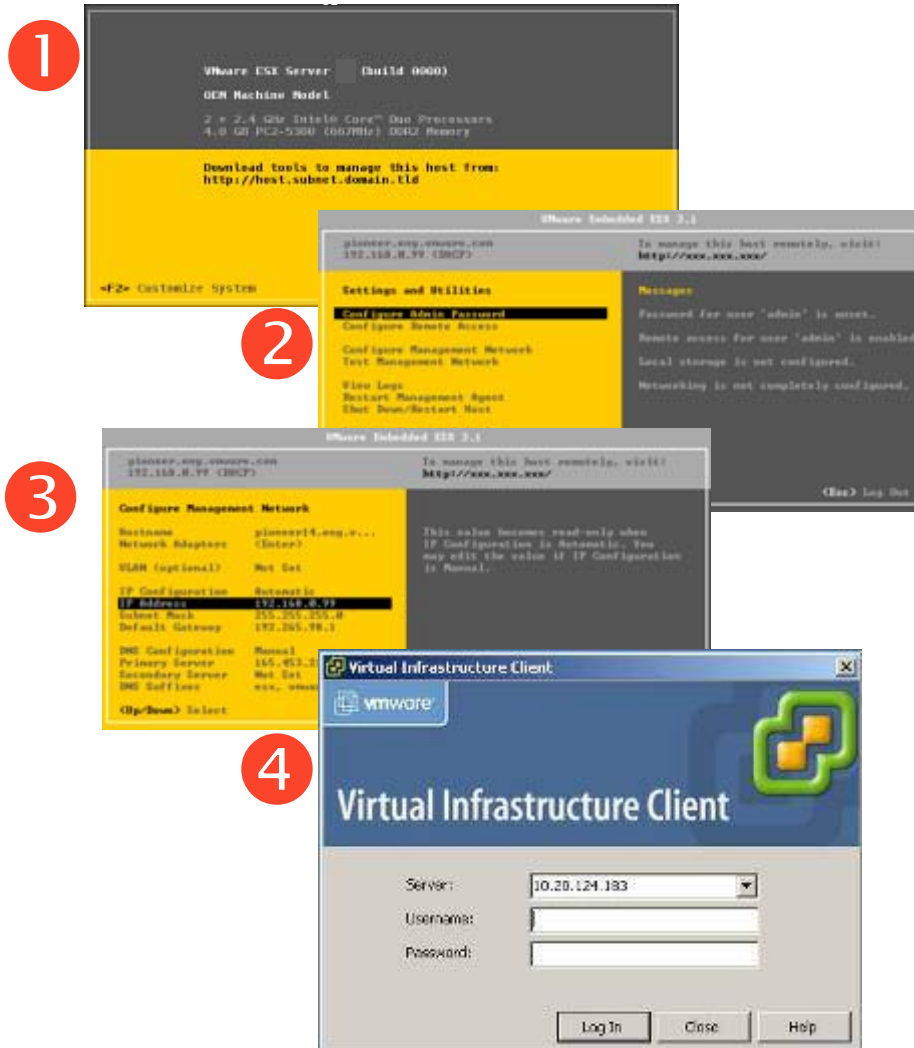

1. VMware ESX Server (Build 0000)
OEM Machine Model
2 x 2.4 GHz Intel® Core™ Duo Processors
4.0 GB PC2-5300 (667MHz) DDR2 Memory
Download tools to manage this host from:
<http://host.subnet.domain.tld>
<F2> Customize System

2. Settings and Utilities
Configure Admin Password
Configure Remote Access
Configure Management Network
Test Management Network
View Logs
Restart Management Agent
Shut Down/Restart Host

3. Configure Management Network
Hostname: ploneer.org.vmx
Network Adapter: (Enter)
VLAN (optional): Not Set
IP Configuration: Automatic
IP Address: 192.168.0.99
Subnet Mask: 255.255.255.0
Default Gateway: 192.255.255.1
DNS Configuration: None
Primary Server: 192.168.0.1
Secondary Server: Not Set
DNS Suffixes: org.vmx
<Up/Down> Select

4. Virtual Infrastructure Client
Server: 10.20.124.183
Username:
Password:
Log In Close Help

1. Power on server and boot into hypervisor
2. Configure Admin Password
3. (optional) Modify network configuration
4. Connect VI Client to IP Address
 - Or manage with VirtualCenter



IBM BladeCenter



Five Products, One Family. 2007+ Innovating for the Next Gen Network

BladeCenter E Ann: Nov 2002



14 Blades in 7U
Enterprise & SMB
Chassis

**Mainstream and
business critical
appl. workloads**

BladeCenter T Ann: Mar 2004



8 Blades in 8U
208VAC / -48VDC
NEBS L3 / ETSI

**Telco, military,
"hardened"
environments**

BladeCenter H Ann: Feb. 2006



14 Blades in 9U
High Speed
(>10Gb)

**Extreme I/O for
data intensive
environment**

BladeCenter HT Ann: Dec 2006



12 Blades in 12U
208VAC / -
48VDCpwr
NEBS Level 3 / ETSI

Total throughput of
600Gbs

**Targeted at core
telecom network**

BladeCenter S Ann: July 2007

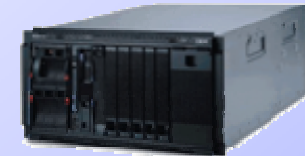

6 Blades in 7U
110/220VAC
Shared SAS/SATA
storage

**Business-in-a
box with
configurable
shared storage**

Common Blades, Common Switches, Common Management



BladeCenter H



System Overview

- 9U Rack Mount
- 14 Blades
- 30 mm slots
- Optimized for 2006+ processors
- Legacy switch bays (qty 4)
- High speed switch bays (qty 4)
- High speed bridge bays (qty 4)
- AMM Support
- 2900 Watt Power supply (N+N redundant)
- 2 Blowers, 12 Fans

- Provide increased power and cooling capability over BC-E
- Provide high speed (**10Gb**) internal fabrics
- Concurrent KVM and media (cKVM/cMedia) capabilities
- **Compatibility with current blades and switches**

BladeCenter H Tour

A Look At The Back

- Two MM slots supporting the Advanced Management Module
- Up to four high speed enabled switch module bays
- Two dedicated bridge modules
- Two shared modules – either bridge or legacy switch
- Up to four legacy switch modules
- Redundant, Hot-Swap blowers
- Two consolidated power inputs
- Light path diagnostic panel
- Aggregated serial connector



Breakthrough **CONNECTIVITY**

MSIM - The Evolution of I/O Connectivity

- Virtualization, multi-core, and clustering are all driving additional port requirements per blade
- **BladeCenter H has inherent hardware capability for eight I/O paths per blade**
- Multi-Switch Interconnect Module provides a means for exploiting existing 8 paths to each blade (HS21, LS21, JS21)
- MSIM fits into the high speed switch slots in BladeCenter H
- Supports standard BladeCenter switch portfolio

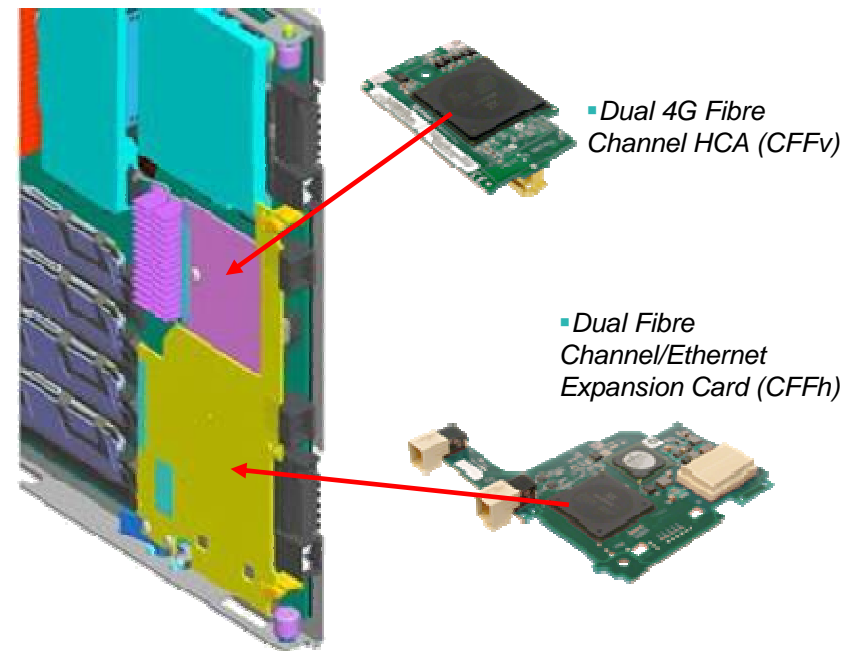

Example Configurations - Summary

6 1G Ethernet
2 4G Fibre Channel

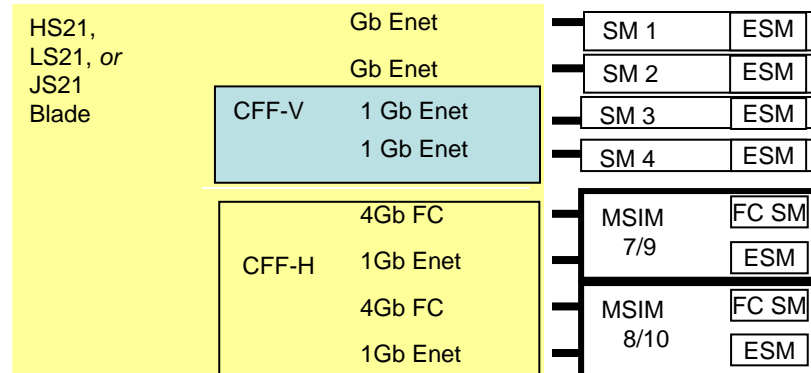

Base NICs

- (1) 39Y9310 Gb Enet CFFV
- (1) 39Y9306 Combo CFFH
- (1) 39Y9314 MSIM

4 1G Ethernet
4 4G Fibre Channel

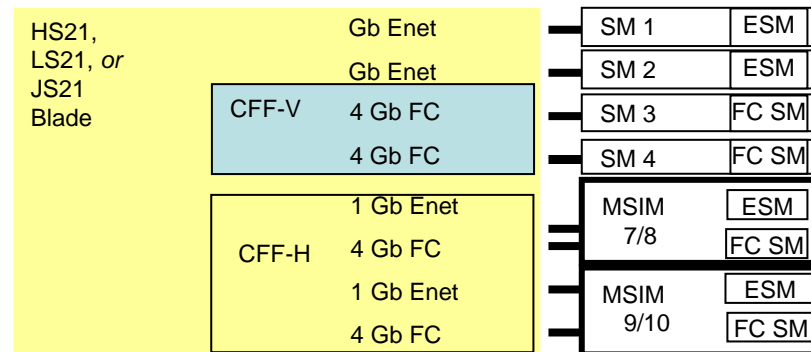

Base NICs

- (1) 41Y8527 4Gb FC CFFV
- (1) 39Y9306 Combo CFFH
- (1) 39Y9314 MSIM



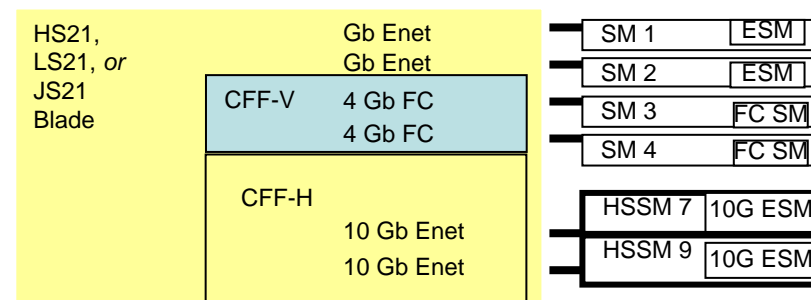











2 1G Ethernet
2 4G Fibre Channel
2 10G Ethernet Channel



Base NICs

- (1) 41Y8527 4Gb FC CFFV
- (1) 39Y9271 10Gb Enet CFFH

Blade Servers

HS21	HS21 XM	LS21	LS41	HC10	QS21	JS22																																																																						
General Purpose Enterprise Blade	Extended Memory Blade for Extra Performance	High Performance Blade Server	Scalable, Enterprise Performance Blade	Mid-High End Workstation Blade	Very High Performance Blade with Cell technology	High Performance Blade with Native Virtualization																																																																						
																																																																												
2 Socket	2 Socket	2 Socket	4 Socket	1 Socket	2 Socket	2 Socket																																																																						
Proc: Xeon 5100 DC Xeon 5300 QC Xeon 5400 QC Mem: 4 DIMM / 16GB HDD: 2 (SAS or SSD)	Proc: Xeon 5100 DC Xeon 5300 QC Xeon 5400 QC Mem: 8 DIMM / 32GB HDD: 1 (SAS or SSD)	Proc: Opteron Mem: 8 DIMM / 32GB HDD: 1	Proc: Opteron Mem: 16 DIMM / 64GB HDD: 2	Proc: Core 2 Duo up to 2.66GHz / 1066MHz Mem: 4 DIMM / 8GB HDD: 60GB SATAII	Proc: 2x 3.2GHz Cell BE Mem: 2GB (1GB / CPU) HDD: None	Proc: 4x 40GHz Power6 cores Mem: 4 DIMM / 32GB HDD: 1 (73/146GB SAS)																																																																						
<u>Sample Applications</u>	<u>Sample Applications</u>	<u>Sample Applications</u>	<u>Sample Applications</u>	<u>Sample Applications</u>	<u>Sample Applications</u>	<u>Sample Applications</u>																																																																						
<ul style="list-style-type: none"> E-mail/ Collab Hosted Client Web Serving 	<ul style="list-style-type: none"> Memory-intensive applications HPC Virtualization SCON 	<ul style="list-style-type: none"> Cluster / HPC Digital Media Modeling & Simulation 	<ul style="list-style-type: none"> Business Intell CRM / PLM Virtualization SCON 	<ul style="list-style-type: none"> CAD Trading floor Collaboration 	<ul style="list-style-type: none"> Cluster / HPC Medical imaging Graphic rendering 	<ul style="list-style-type: none"> AIX/Linux Applications Cluster / HPC VirtualSCON 																																																																						
																																																																												
<table border="0"> <tr><td>HPC</td><td></td></tr> <tr><td>Web 2/3D</td><td></td></tr> <tr><td>BPC</td><td></td></tr> <tr><td>Bus. App.</td><td>HS21</td></tr> <tr><td>Infr. App.</td><td></td></tr> </table>	HPC		Web 2/3D		BPC		Bus. App.	HS21	Infr. App.		<table border="0"> <tr><td>HPC</td><td></td></tr> <tr><td>Web 2/3D</td><td></td></tr> <tr><td>BPC</td><td>HS21 XM</td></tr> <tr><td>Bus. App.</td><td></td></tr> <tr><td>Infr. App.</td><td></td></tr> </table>	HPC		Web 2/3D		BPC	HS21 XM	Bus. App.		Infr. App.		<table border="0"> <tr><td>HPC</td><td>LS21</td></tr> <tr><td>Web 2/3D</td><td></td></tr> <tr><td>BPC</td><td></td></tr> <tr><td>Bus. App.</td><td></td></tr> <tr><td>Infr. App.</td><td></td></tr> </table>	HPC	LS21	Web 2/3D		BPC		Bus. App.		Infr. App.		<table border="0"> <tr><td>HPC</td><td>LS41</td></tr> <tr><td>Web 2/3D</td><td></td></tr> <tr><td>BPC</td><td></td></tr> <tr><td>Bus. App.</td><td></td></tr> <tr><td>Infr. App.</td><td></td></tr> </table>	HPC	LS41	Web 2/3D		BPC		Bus. App.		Infr. App.		<table border="0"> <tr><td>HPC</td><td></td></tr> <tr><td>Web 2/3D</td><td></td></tr> <tr><td>BPC</td><td></td></tr> <tr><td>Bus. App.</td><td>HC10</td></tr> <tr><td>Infr. App.</td><td></td></tr> </table>	HPC		Web 2/3D		BPC		Bus. App.	HC10	Infr. App.		<table border="0"> <tr><td>HPC</td><td>QS21</td></tr> <tr><td>Web 2/3D</td><td></td></tr> <tr><td>BPC</td><td></td></tr> <tr><td>Bus. App.</td><td></td></tr> <tr><td>Infr. App.</td><td></td></tr> </table>	HPC	QS21	Web 2/3D		BPC		Bus. App.		Infr. App.		<table border="0"> <tr><td>HPC</td><td>JS22</td></tr> <tr><td>Web 2/3D</td><td></td></tr> <tr><td>BPC</td><td></td></tr> <tr><td>Bus. App.</td><td></td></tr> <tr><td>Infr. App.</td><td></td></tr> </table>	HPC	JS22	Web 2/3D		BPC		Bus. App.		Infr. App.	
HPC																																																																												
Web 2/3D																																																																												
BPC																																																																												
Bus. App.	HS21																																																																											
Infr. App.																																																																												
HPC																																																																												
Web 2/3D																																																																												
BPC	HS21 XM																																																																											
Bus. App.																																																																												
Infr. App.																																																																												
HPC	LS21																																																																											
Web 2/3D																																																																												
BPC																																																																												
Bus. App.																																																																												
Infr. App.																																																																												
HPC	LS41																																																																											
Web 2/3D																																																																												
BPC																																																																												
Bus. App.																																																																												
Infr. App.																																																																												
HPC																																																																												
Web 2/3D																																																																												
BPC																																																																												
Bus. App.	HC10																																																																											
Infr. App.																																																																												
HPC	QS21																																																																											
Web 2/3D																																																																												
BPC																																																																												
Bus. App.																																																																												
Infr. App.																																																																												
HPC	JS22																																																																											
Web 2/3D																																																																												
BPC																																																																												
Bus. App.																																																																												
Infr. App.																																																																												

HS21 XM Blade server

- Processor:
Dual and Quad-Core processors
 - 65W and 80W Woodcrest (DC)
 - 1.60-3.00GHz
 - 80W Clovertown (QC)
 - 1.60-2.33GHz
 - 80W Harpertown (QC)
 - 2.00-3.00GHz
- Memory: 8 FB DIMMs (32GB Max)
- Storage: SAS HDD (73, 146GB) or 16GB SSD
- Network: 2 NICs - Broadcom 5708S (TOE enabled)
- Diskless ready:
 - iSCSI and SAN boot for all OS
 - Support for IBM Modular Flash Device 4GB
- Supports Concurrent KVM Mezzanine Card (cKVM)
- Supports PEU2 and SIO Expansion Units
- Support for the new MSIM Combo Form Factor (CFF) card to double port count per blade

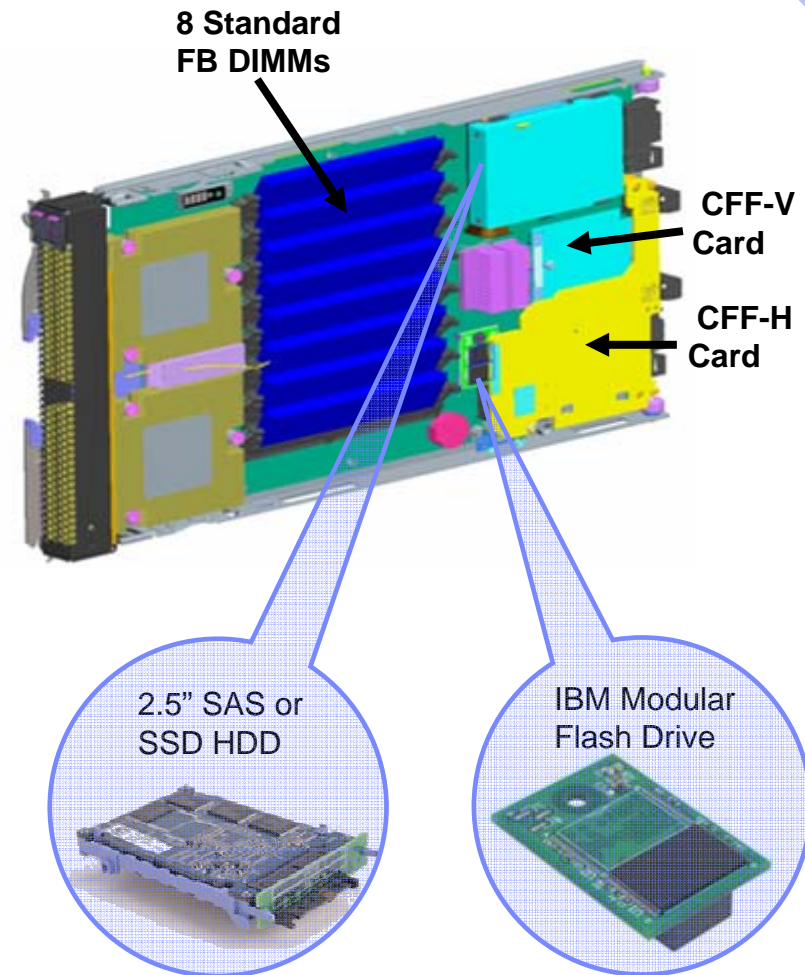

The RIGHT choice with IBM Solid State Drives

Increase availability and efficiency with Solid State Drives

- **Superior uptime**

- 3X the availability of mechanical drives with RAID-1
- No moving parts to fail
- Enterprise wear leveling to extend life even further



- **Less power and heat than conventional disk drives—up to 87%**

- **Flexible deployment with full OS support**

- Operates as a standard hard disk drive
 - Supports Linux[®], Windows[®] and VMware[®]
- Works in standard drive bay

**IBM 16GB Dual
Solid State Drive**

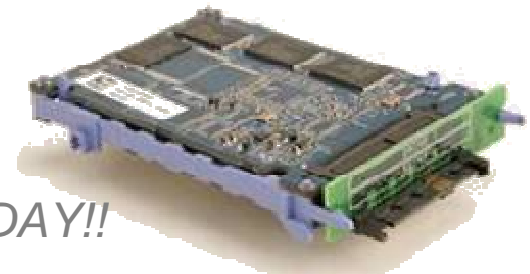

IBM Solid State Drives: next generation technology TODAY!!

The right design for Solid State Drives with RAID

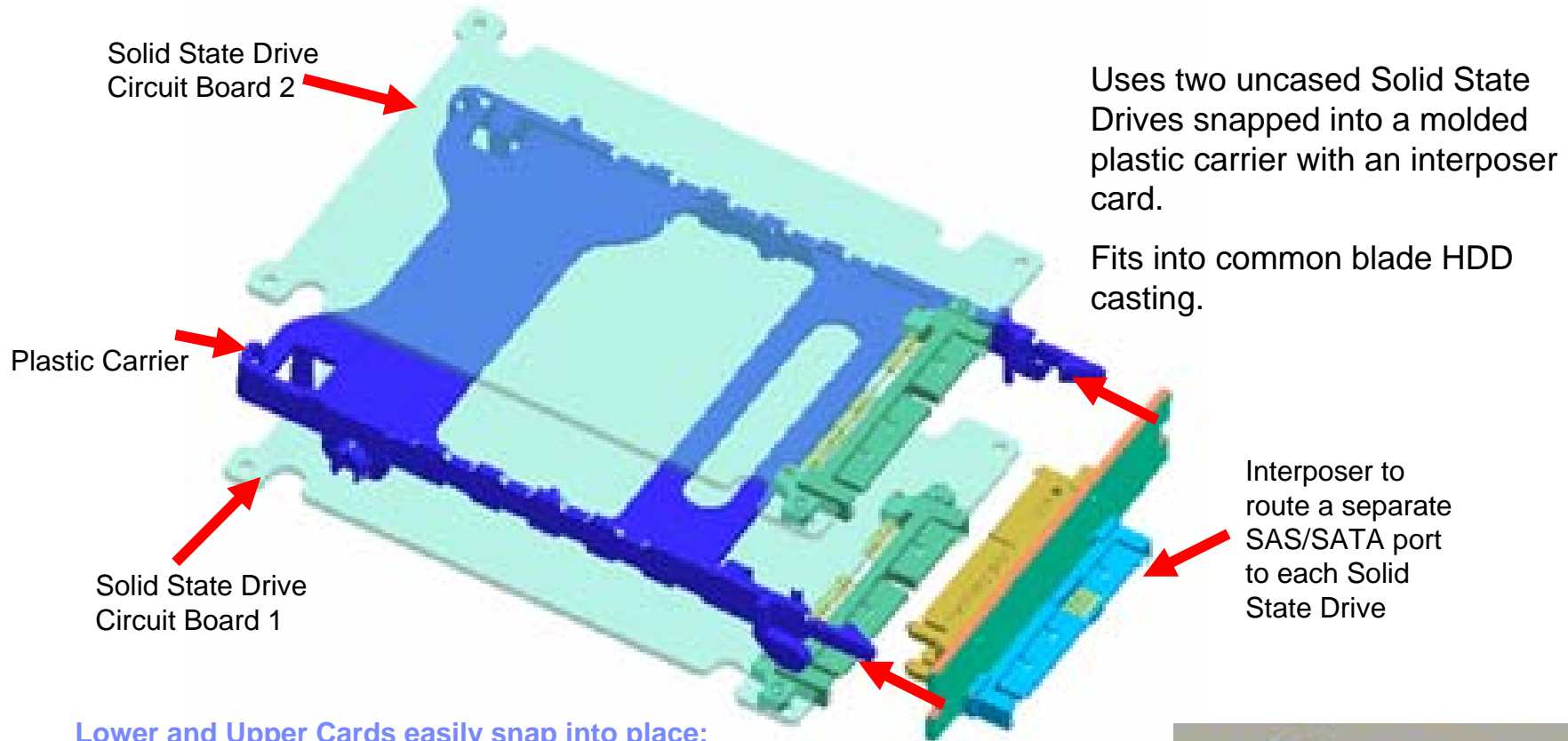

Uses two uncased Solid State Drives snapped into a molded plastic carrier with an interposer card.

Fits into common blade HDD casting.

Interposer to route a separate SAS/SATA port to each Solid State Drive

Lower and Upper Cards easily snap into place; Solid State Drive connectors dock into Interposer while the Interposer snaps into place.

Mirroring is hardware mirroring (LSI 1064 SAS Controller), similar to SAS Drives and can be disabled

Installs into present blade HDD tray casting



Virtualization – To Blade or Not to Blade

A holistic approach

IBM BladeCenter

- Total Infrastructure consolidation
- Best when concerned about aggregation – “too many eggs in one basket”
- Choose when OS images average less than 2GB of memory per VM
- Low power, heat, super dense
- Balanced system performance
- Scale out

IBM eX4

- High end virtualizations
- Best when hosting multiple high performance VMs
- Choose when OS images average more than 2GB of memory per VM or has SMP VM's
- Fewest number of systems to manage
- Truly scalable, balanced system
- Scale up

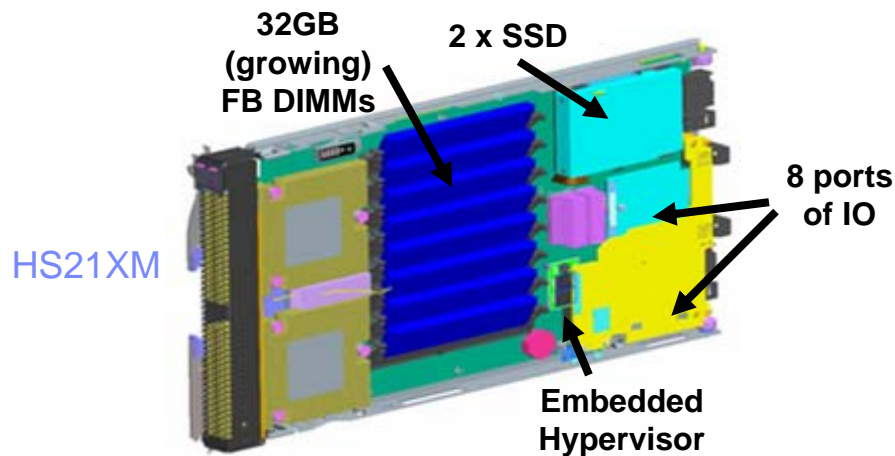

x3850 M2

or

X3950 M2



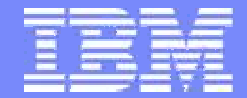

IBM System x and BladeCenter

Close ... Thank you

